

30 906

DN 50-200 PN=1,0-1,6

DN 250, 300 PN=1,0

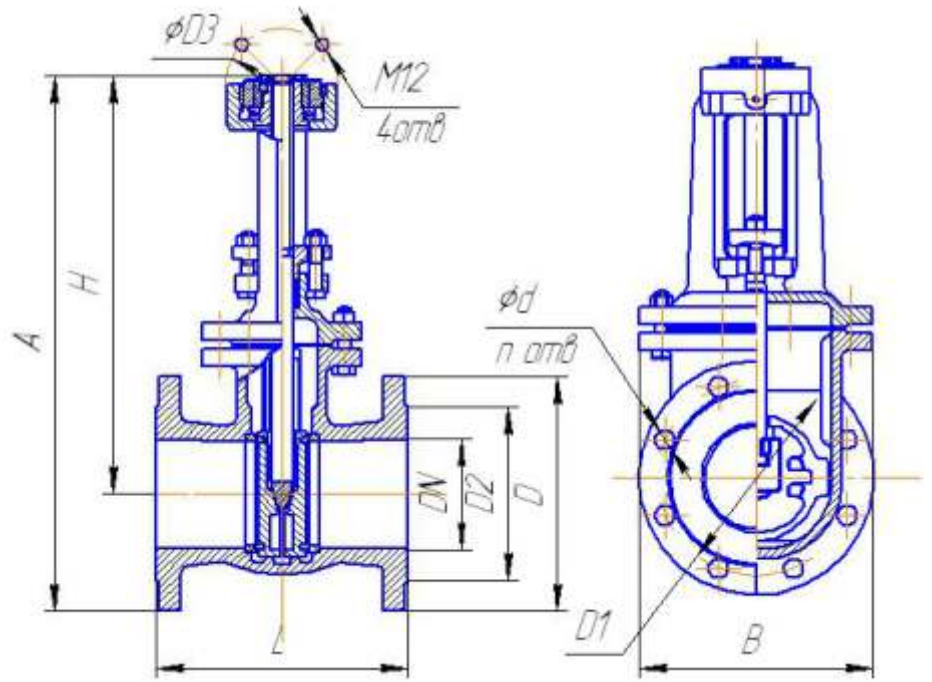

12817

I, 2 12815.

+225⁰

«D» 9544.

20 1412;

-59 15527.

()

- 2, 4 15150.

5762 3721-001-00324292-2011.

10

DN	D	D1	D2	D3	L	H	d	n	A	B	
50	125*125	125	102	104	180	250	18	4	320	125	12
80	150*150	160	133	104	210	315	18	4	385	172	19
100	215	180	158	104	230	385	18	8	485	214	30
125	245	210	184	104	255	430	18	8	550	248	40
150	280	240	212	104	280	505	22	8	640	284	57
200	335	295	268	135	330	650	22	8/12*	820	360	97
250	390	350	320	135	450	810	22	12	1010	452	180
300	440	400	370	135	500	915	22	12	1150	516	260

* -n = 12 Pp 1.6 ()

“

”

/

(83162) 570-90; 510-90, 536-70